

Multi Hybrid Control Panel
AW-RP505

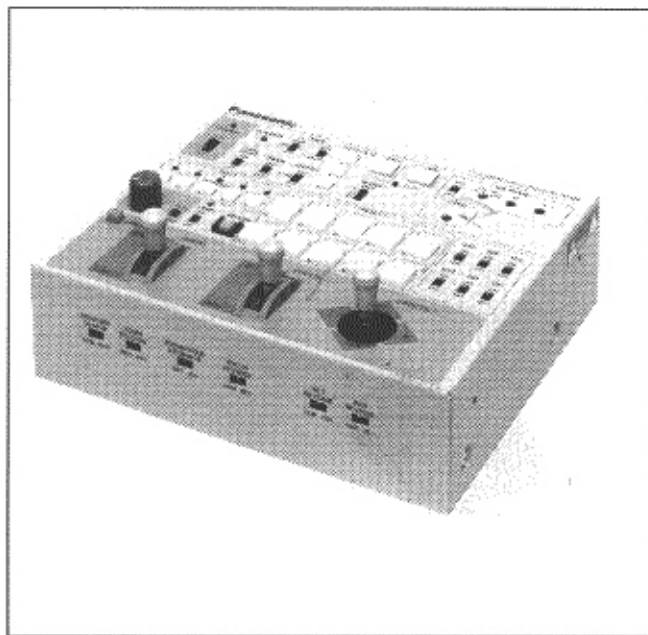

Operating Instructions

Panasonic®

Before attempting to connect or operate this product,
please read these instructions completely.



CAUTION

RISK OF ELECTRIC SHOCK
DO NOT OPEN



CAUTION:

TO REDUCE THE RISK OF ELECTRIC SHOCK, DO NOT REMOVE COVER (OR BACK). NO USER SERVICEABLE PARTS INSIDE.

REFER SERVICING TO QUALIFIED SERVICE PERSONNEL.



SA 1965

The lightning flash with arrowhead symbol, within an equilateral triangle, is intended to alert the user to the presence of uninsulated "dangerous voltage" within the product's enclosure that may be of sufficient magnitude to constitute a risk of electric shock to persons.



SA 1966

The exclamation point within an equilateral triangle is intended to alert the user to the presence of important operating and maintenance (servicing) instructions in the literature accompanying the appliance.

For U.S.A.

Warning:

Do not install this product near any object that burns easily. In case of using a halogen lamp, installation of it near such an object could cause a fire due to the heat generated by the lamp.

For CANADA

This digital apparatus does not exceed the Class A limits for radio noise emissions from digital apparatus set out in the Radio Interference Regulations of the Canadian Department of Communications.

The serial number of this product may be found on the bottom of the unit.

You should note the serial number of this unit in the space provided and retain this book as a permanent record of your purchase to aid identification in the event of theft.

Model No. _____

Serial No. _____

WARNING:

TO PREVENT FIRE OR ELECTRIC SHOCK HAZARD, DO NOT EXPOSE THIS APPLIANCE TO RAIN OR MOISTURE.

CONTENTS

FEATURES	2
PRECAUTIONS	3
MAJOR OPERATING CONTROLS AND THEIR FUNCTIONS	4
INSTALLATION OF PAN/TILT HEAD	19
CONNECTIONS	22
OPERATING PROCEDURES	26
RACK MOUNTING	34
SPECIFICATIONS	36
ACCESSORIES	37

FEATURES

- The Multi Hybrid Control Panel AW-RP505 is combined with the Multiport Hub (AW-HB505) to control up to five Pan/tilt Heads (AW-PH300) and Color Video Cameras (AW-E560). With the Control Panel AW-RP505 connected to the multiport hub with three coaxial cables (5C-2V) and a single 10BASE-T straight cable (UTP category 5), and with the Multiport Hub connected to each camera and pan/tilt head with three coaxial cables (5C-2V) and a single 10BASE-T straight cable (UTP category 5), the Control Panel performs various kinds of control on the cameras and pan/tilt heads, and sends and receives camera video signals and genlock signals.
- The maximum cable length from this control panel to the Multiport Hub is 10 meters. The maximum cable length between the multiport hub and the cameras and pan/tilt heads is 500 meters.
- Head pan/tilt and lens zoom/focus can be controlled at varying speeds with the servo control, and can be pre-set at up to 10 points per pan/tilt head.
- With the auxiliary control input connector (AUX CONTROL IN), pan/tilt, zoom, focus, and iris operations can be externally controlled.

PRECAUTIONS

- **Use only with AC Adaptor AW-PS301.**
- **Handle the control panel with care.**
Dropping the control panel or subjecting it to a strong shock can cause a failure or an accident.
- **Operating temperature range -10°C to $+45^{\circ}\text{C}$**
Avoid using it in a cold place below -10°C or a hot place above $+45^{\circ}\text{C}$ because low or high temperature will adversely affect the parts inside.
- **Switch power off before power cable connection or disconnection.**
Be sure to switch power off before connecting or disconnecting the power cable.
- **Avoid outdoor use.**
- **Install the control panel more than 1 meter away from the monitors.**

- **Care**

Pull out the power cable plug, and wipe the control panel clean with a dry cloth. If it is extremely dirty, dip a cloth into a diluted solution of kitchen detergent, squeeze it hard, and wipe the product surfaces carefully.

Note

- Do not use benzine, paint thinner, or other volatile liquids.
- When using a chemical duster, carefully read the caution notes on its use.

Precautions in Using Halogen Lamp

Set the power control switch to the OFF position after setting the lamp switch to the OFF position. Halogen lamp power will not be switched off if the AC adapter for the AW-RP505 is disconnected or if the main circuit breaker is opened while the halogen lamp is in use.

MAJOR OPERATING CONTROLS AND THEIR FUNCTIONS

■ Control Panel

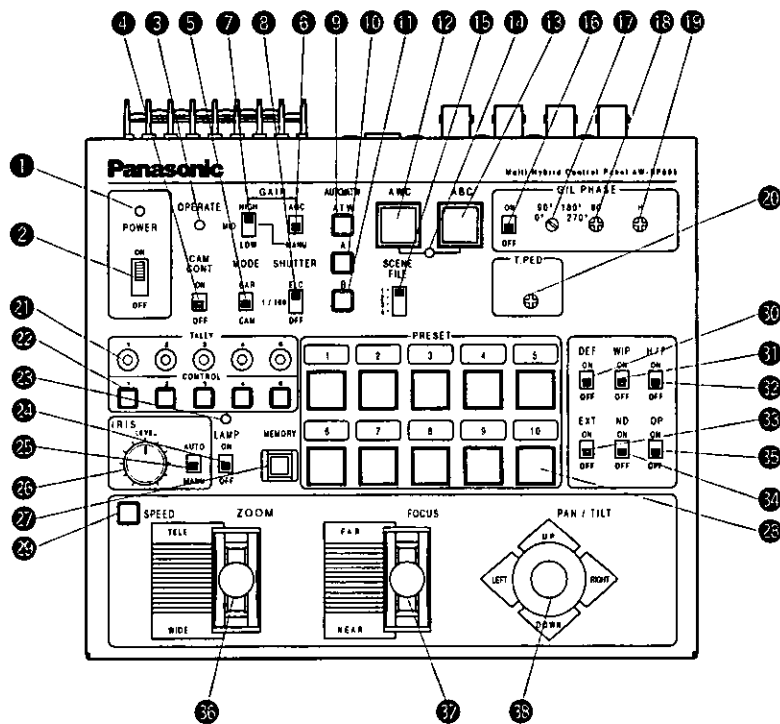

Note: To control the cameras and pan/tilt head, the power switch on the Multiport Hub must be in the ON position.

Only the camera and pan/tilt head selected with CONTROL Switch 22 can be set and controlled. First, select a camera with CONTROL Switch 22 set CAM CONT Switch 4 to the ON position, and make the necessary settings. After setting the camera, set CAM CONT Switch 4 back to the OFF position.

1 Power Indicator [POWER]

Lights red when POWER ON/OFF Switch 2 is in the ON position, and goes out when the same switch is set to the OFF position.

2 Power CONTROL Switch [POWER, ON/OFF]

All the connected cameras and pan/tilt heads are switched on when this switch is set to the ON position. (The power indicator lights.) The camera and pan/tilt head are partially switched off when this switch is set to the OFF position.

Note: When the switch is set to the OFF position, the camera is totally switched off but the communication line between the pan/tilt head and this control panel remains live. To disconnect all power supply, pull out the power plug from the electrical outlet.

3 Operating Indicator [OPERATE]

Lights green when communication begins normally between the camera and the control panel, and goes out if a communication error occurs.

4 Camera Control Switch [CAM CONT, ON/OFF]

Before making camera settings, select a camera with CONTROL Switch 22 then set CAM CONT Switch 4 to the ON position. After making the necessary settings, set CAM CON Switch 4 back to the OFF position.

Note: At the same time as CAM CONT Switch 4 is set to the ON position, all the switch settings of this

control panel are sent to the selected camera to update its settings. Do not shift CAM CONT Switch 4 to the ON position except when changing the camera settings. If a different camera is selected with CONTROL Switch 22 when CAM CONT Switch 4 is in the ON position, the settings of the newly selected camera will also be changed. Before selecting another camera with CONTROL Switch 22, be sure to set CAM CONT Switch 4 back to the OFF position.

5 Mode Selection Switch [MODE, BAR/CAM]

Used to select camera color bar signals or camera video signals. Select a camera with CONTROL Switch 22, set CAM CONT Switch 4 to the ON position, then select the desired type of signal with this switch. With the switch set to BAR, the control panel outputs color bar signals from the video output terminal. When the switch is set to CAM, it outputs camera video signals. After selecting it, set CAM CONT Switch 4 back to the OFF position.

6 AGC Selection Switch [GAIN, AGC/MANU]

Keep this switch in the AGC position if you want to keep automatic gain control. Select a camera with CONTROL Switch 22, set CAM CONT Switch 4 to the ON position, then select AGC or MANU as necessary. When this switch is at AGC GAIN H/M/L switch 7 is invalid. After selecting it, set CAM CONT Switch 4 back to the OFF position.

7 Gain Selection Switch [GAIN, HIGH/MID/LOW]

This switch is valid only when GAIN AGC/MANU Switch 6 is in the MANU position. Select a camera with CONTROL Switch 22, set CAM CONT Switch 4 to the ON position, then select HIGH, MID, or LOW. Normally, keep it in the LOW position. When the camera is used in a dark place or when video output level is not high enough even if the iris is wide open, set the switch to the MID or HIGH position. After selecting it, set CAM CONT Switch 4 back to the OFF position.

8 Electronic Shutter Speed Selection Switch [SHUTTER, ELC/ 1/100 /OFF]

Used to select a mode of camera electronic shutter control. Select a camera with CONTROL Switch 22, set CAM CONT Switch 4 to the ON position, then select ELC, 1/100, or OFF. With the switch in the ELC position, the electronic shutter is controlled and the camera sensitivity is automatically adjusted when using the camera in a bright place. The shutter speed is 1/100 second when the switch is in the 1/100 position. The electronic shutter is off when the switch is in the OFF position. After selecting it, set CAM CONT Switch 4 back to the OFF position.

9 White Balance ATW Selection Switch [AUTO/ATW, ATW]

When this switch is depressed, the camera selected with CONTROL Switch 22 keeps automatically adjusting white balance. The switch lights when it is selected.

10 White Balance Ach Selection Switch [AUTO/ATW, A]

When this switch is pressed, white balance will be as stored in Channel A of the camera selected with CONTROL Switch 22. The switch lights when it is selected. When AWC switch 12 is pressed after selecting AUTO/ATW, A, white balance is automatically adjusted and stored in Channel A.

11 White Balance Bch Selection Switch [AUTO/ATW, B]

When this switch is depressed, white balance will be as stored in Channel B of the camera selected with CONTROL Switch 22. The switch lights when it is selected. When AWC switch 12 is pressed after selecting AUTO/ATW, B, white balance is automatically adjusted and stored in Channel B.

12 Auto White Start Switch [AWC]

If this switch is pressed when AUTO/ATW A Switch 10 or AUTO/ATW B Switch 11 is selected, white balance is automatically adjusted on the camera selected with CONTROL Switch 22. The adjustment results are stored in Channel A or B. This switch is invalid if the MODE BAR/CAM switch 5 is in the BAR position. Auto Set Indicator 14 flashes while AWC is in operation, and goes out when white balance has been properly adjusted. Auto Set Indicator 14 remains lit if white balance adjustment fails.

Note: White balance may not be adjustable if there is no white in the image being taken by the camera. For details, refer to the Operating Instructions for the Camera.

13 Auto Black Start Switch [ABC]

When this switch is depressed, the lens iris is automatically closed to set black balance on the camera selected with CONTROL Switch 22. Be sure to keep the IRIS AUTO/MANU switch 25 in the AUTO position in setting black balance. Auto Set Indicator 14 flashes while ABC is in operation, and goes out when black balance has been properly adjusted. Auto Set Indicator 14 remains lit if black balance adjustment fails. Black balance adjustment may fail if the total pedestal is too low. In such a case, adjust the total pedestal with T.PED Control 20 (referring to the Operating Procedures at page 26 and try to adjust black balance again.

14 Auto Set Indicator

This LED flashes during white balance or black balance adjustment with AWC Switch 12 or ABC Switch 13 depressed, and goes out when the adjustment has ended normally. The LED remains lit if balance adjustment fails.

15 Scene File Selection Switch [SCENE FILE, 1/2/3/4]

Select a scene file preset on the camera side. Remember, however, that [4] is camera scene file USER A or USER B (provided that or AW-E560 is connected).

16 Genlock Phase Control Switch [G/L PHASE, ON/OFF]

Used to adjust the genlock phase in operating the camera in external sync mode. Select a camera with CONTROL Switch 22, set CAM CONT Switch 4 to the ON position, then set G/L PHASE Switch 16 to the ON position. After G/L phase setting, set CAM CONT Switch 4 and G/L PHASE Switch 16 back to the OFF position.

Note: If G/L PHASE Switch 16 is set to the ON position when CAM CONT Switch 4 is at ON, the genlock phase setting data of this control panel is sent to the camera to update its genlock phase settings. Do not shift G/L PHASE Switch 16 to the ON position except when changing the camera genlock phase settings. If a different camera is selected with CONTROL Switch 22 when both CAM CONT Switch 4 and G/L PHASE Switch 16 are in the ON position, the genlock phase settings of the newly selected camera will be similarly changed. Before changing the camera for another, set G/L PHASE Switch 16 back to the OFF position.

17 Genlock Subcarrier Phase Coarse Switch [G/L PHASE, 0°/90°/180°/270°]

Used for coarse adjustment of the color phases of genlock input and video output signals in operating the camera in external sync mode. Used in combination with G/L PHASE SC Control 18, the switch has an

adjustment range of over 360°. Before making an adjustment, set CAM CONT Switch ④ and G/L PHASE Switch ⑮ to the ON position. After the adjustment, set both CAM CONT Switch ④ and G/L PHASE Switch ⑮ back to the OFF position.

⑮ Genlock Subcarrier Phase Fine Control
[G/L PHASE, SC]

Used for fine adjustment of the color phases of genlock input and video output signals in operating the camera in external sync mode. Use this switch in combination with G/L PHASE Coarse Switch ⑰. Before making an adjustment, set CAM CONT Switch ④ and G/L PHASE Switch ⑮ to the ON position. After the adjustment, set both CAM CONT Switch ④ and G/L PHASE Switch ⑮ back to the OFF position.

⑰ G/L Horizontal Phase Adjustment Control
[G/L PHASE, H]

Used to adjust the horizontal phases of genlock input and video output signals in operating the camera in external sync mode. Before making a horizontal phase adjustment, set CAM CONT Switch ④ and G/L PHASE Switch ⑮ to the ON position.

⑳ Total Pedestal Level Control [T.PED]

The set pedestal level of the camera's Y (luminance) signal can be adjusted. This control is used in a system of two or more cameras to adjust the pedestal levels of these cameras. Select a camera with CONTROL

Switch ㉒, set CAM CONT Switch ④ to the ON position, then adjust the total pedestal level with T.PED Control ㉑. The control may operate not continuous sometimes due to digital signal processing. After the adjustment, set CAM CONT Switch ④ back to the OFF position.

㉑ Tally Indicator [TALLY]

When a tally signal is input from a special effect generator (SEG) or video switcher, for example, to any of the jacks [1] to [5] of TALLY Terminal ㉓, the corresponding LED lights red.

㉒ Camera/Pan/tilt Head Selection Switch [CONTROL]

Select a desired camera with pan/tilt head from among those connected to the control panel. When a camera with pan/tilt head is selected by pressing one of the buttons [1] to [5], the pressed button lights.

Note: Even if an unconnected camera with pan/tilt head is selected by pressing the corresponding button, the button lights.

㉓ Lamp Indicator [LAMP]

Lights red when LAMP ON/OFF Switch ㉔ is in the ON position. Flashes if the lamp connected to the AC adapter (AW-PS300) for the pan/tilt head selected with CONTROL Switch ㉒ is broken. Goes out when LAMP ON/OFF Switch ㉔ is set to the OFF position

Caution: In connecting a halogen lamp to the Pan/tilt Head AC Adaptor (AW-PS300), make sure that it is in the wattage range of 250 to 500W. If a halogen lamp less than 250W is used, the LED may flash when LAMP ON/OFF Switch 24 is in the on position even if the lamp is normal.

24 Lamp Switch [LAMP, ON/OFF]

Switches on and off the halogen lamp connected to the lamp AC receptacle of the pan/tilt head AC adapter (AW-PS300). Select a pan/tilt head with CONTROL Switch 22, then switch the halogen lamp on or off as necessary. Set it to the ON position to switch the halogen lamp on (in which case, the lamp Indicator flashes). Set it to the OFF position to switch the halogen lamp off.

Note: When a pan/tilt head is selected with CONTROL Switch 22, the halogen lamp connected to the AC adapter for the pan/tilt head selected with that switch lights or goes out depending on the position of LAMP ON/OFF Switch 24.

25 Lens Iris Selection Switch [IRIS, AUTO/MANU]

Used to select AUTO or MANU mode in adjusting the lens iris connected to the selected camera and pan/tilt head. When this switch is in the AUTO position, the lens iris is automatically controlled according to the quantity of light entering the lens. When the switch is in the MANU position, the iris can be manually controlled over the range from the closed position to the fully open position using IRIS LEVEL Control 26.

Set the switch to the MANU position in storing iris data in PRESET Switch 23 with MEMORY Switch 27. If the switch is in the AUTO position, iris data will not be stored in the memory.

26 Lens Iris Control [IRIS, LEVEL]

When IRIS AUTO/MANU Switch 25 is in the MANU position, the iris can be controlled over the range from the closed position to the fully open position using this control. Turning it clockwise opens the iris and turning it counterclockwise closes the iris.

If the camera is preset to AUTO IRIS ADJ ON when IRIS AUTO/MANU Switch 25 is in the AUTO position, this control may be used for fine adjustment of ALC focus level. For details, refer to the Operating Instructions for the Camera.

If the preset memory is called by pressing PRESET Switch 23 when IRIS AUTO/MANU Switch 25 is in the MANU position, the iris is adjusted to the preset value stored in the memory regardless of the position of this control. If the control is turned after that, the iris is adjusted corresponding to the position of the control.

27 Preset Memory Switch [MEMORY]

Head pan/tilt positions, lens zoom/focus/iris (provided that IRIS AUTO/MANU Switch 25 is in the MANU position), and camera white balance (ATW, Channel A or B) can be preset in up to 10 memory buttons per pan/tilt head.

To preset them in these buttons, first select a camera and pan/tilt head with CONTROL Switch 22, then select a head pan/tilt position, lens zoom/focus/iris, or camera white balance (ATW Channel A or B); press MEMORY Switch 27 (so it lights yellow green and all the 10 buttons of PRESET Switch 28 flash); while keeping the MEMORY Switch 27 depressed, press one of the 10 buttons of PRESET Switch 28 as desired. The pressed button in which the selected item is stored lights.

28 Preset Position Selection Switch [PRESET]

The head pan/tilt positions, lens zoom/focus/iris, and camera white balance that are stored in the buttons of PRESET Switch 28 can be recalled to operate the pan/tilt head, the lens, and the camera according to the preset data.

To preset them in the PRESET switches, first select a camera and pan/tilt head with CONTROL Switch 22, then select a head pan/tilt position, lens zoom/focus/iris, or camera white balance (ATW Channel A or B); press the MEMORY Switch 27 (so it lights yellow green and all the 10 buttons of PRESET Switch 28 flash); at the same time press one of the 10 buttons of PRESET Switch 28 as desired. The pressed button in which the selected item is stored lights.

29 Speed Selection Switch [SPEED]

If ZOOM lever 35, FOCUS Lever 37, or PAN/TILT Lever 38 is moved while keeping SPEED Switch 29 depressed, the corresponding operation takes place

at low speed, provided that SPEED SW CHANGE Switch 49 is in the LOW position. If one of these levers is moved with SPEED Switch 29 depressed when SPEED SW CHANGE Switch 49 is in the HIGH position, the corresponding operation takes place at high speed. SPEED Switch 29 remains lit while it is kept depressed.

30 Defroster Switch [DEF, ON/OFF]

If this switch is connected to a pan/tilt head with a built-in defroster function, it switches on and off the defroster.

Note: At the same time as a pan/tilt head is selected with CONTROL Switch 22, the defroster of the selected pan/tilt head is switched on or off depending on the position of DEF ON/OFF Switch 30.

31 Wiper Switch [WIP, ON/OFF]

If this switch is connected to a pan/tilt head with a built-in wiper function, it switches on and off the wiper.

Note: At the same time as a pan/tilt head is selected with CONTROL Switch 22, the wiper of the selected pan/tilt head is switched on or off depending on the position of WIPE ON/OFF Switch 31.

32 Heater/Fan Switch [H/F, ON/OFF]

If this switch is connected to a pan/tilt head with a built-in heater or fan function, it switches on and off the heater or fan.

Note: At the same time as a pan/tilt head is selected with CONTROL Switch 22, the heater or fan of the selected pan/tilt head is switched on or off depending on the position of H/F ON/OFF Switch 32.

33 Lens Extender Switch [EXT, ON/OFF]

If this switch is connected to a lens with a built-in extender function, it switches on and off the lens extender. For details, refer to the Operating Instructions for the Lenses and Pan/tilt Head.

Note: At the same time as a pan/tilt head is selected with CONTROL Switch 22, the lens extender of the selected pan/tilt head is switched on or off depending on the position of EXT ON/OFF Switch 33.

34 ND Filter Switch [ND, ON/OFF]

If this switch is connected to a lens with a built-in ND filter function, it switches on and off the ND filter. For details, refer to the Operating Instructions for the Lenses and Pan/tilt Head.

Note: At the same time as a pan/tilt head is selected with CONTROL Switch 22, the ND filter of the selected pan/tilt head is switched on or off depending on the position of ND ON/OFF Switch 34.

35 Option Switch [OP, ON/OFF]

Controls the option switch terminal on the pan/tilt head AC adapter (AW-PS300) to short circuit or open it. That is, the option switch terminal is shorted when OP ON/OFF Switch 35 is in the ON position, or is opened when it is in the OFF position. For details, refer to the Operating Instructions for the Pan/tilt Head AC Adapter.

Note: At the same time as a pan/tilt head is selected with CONTROL Switch 22, the option switch terminal on the selected pan/tilt head is shorted or opened depending on the position of OP ON/OFF Switch 35.

36 Zoom Lever [ZOOM, TELE/WIDE]

Used to control the zoom operation of the lens that is connected to the pan/tilt head selected with CONTROL Switch 22. Zoom speed varies according to the angle of the lever. The lens moves toward TELE when the lever is moved toward TELE, or toward WIDE when the lever is moved toward WIDE, provided that ZOOM REVERSE Switch 50 is in the NOR position. When ZOOM REVERSE Switch 50 is set to the REV position, the lens moves in the opposite direction. ZOOM/FOCUS EXCHANGE Switch 51 may be used to exchange its function with FOCUS Lever 37.

37 Focus Lever [FOCUS FAR/NEAR]

Used to adjust the focus of the lens that is connected to the pan/tilt head selected with CONTROL Switch 22. Used to adjust the lens focus at varying speed depending on the angle of the lever. The lens is focused far when the lever is moved toward FAR, or near when the lever is moved toward NEAR, provided that FOCUS REVERSE Switch 52 is in the NOR position. When FOCUS REVERSE Switch 52 is set to the REV position, the lens focus operates in the opposite direction. ZOOM/FOCUS EXCHANGE Switch 51 may be used to exchange its function with ZOOM Lever 56.

38 Pan/tilt Lever [PAN/TILT, UP/DOWN/LEFT/RIGHT]

Used to control the pan/tilt operation of the pan/tilt head selected with CONTROL Switch 22. Controls the head's pan/tilt operation at varying speed depending on the angle of the lever. The pan/tilt head turns up when the lever is moved toward UP, or down when it is moved toward DOWN, provided that TILT REVERSE Switch 53 is in the NOR position. The pan/tilt head moves in the opposite direction if the TILT REVERSE Switch 53 is in the REV position. The pan/tilt head turns leftward when the lever is moved toward LEFT, or rightward when it is moved toward RIGHT, provided that PAN REVERSE Switch 54 is in the NOR position. The pan/tilt head moves in the opposite direction if the PAN REVERSE Switch 54 is in the REV position.

Note: TILT REVERSE Switch 53 and PAN REVERSE Switch 54 may be used to reverse the operating direction of the pan/tilt head, but be sure to set the operating direction of the pan/tilt head with its mounting direction selection switch during its installation depending on whether the pan/tilt head is mounted on the floor or is suspended. Unless the mounting direction selection switch on the pan/tilt head is properly set, the pan/tilt head will pan or tilt in the opposite direction and the pan/tilt head operation limiters will not be properly stored in the memory. For details on the setting of this switch, refer to INSTALLATION OF PAN/TILT HEAD at page 19 or the Operating Instructions for the Pan/tilt Head.

■ REAR PANEL

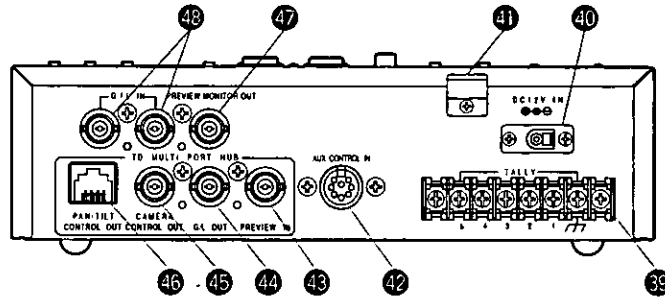

- 39 TALLY Terminal [TALLY] (6-pin Terminal Board)**
Connect it to the tally connector on a special effect generator (SEG) or a video switcher, for example. When the voltage of any of the jacks [1] to [5] of the terminal falls to the ground level, the corresponding TALLY Indicator 21 and the Tally Indicator on the Pan/tilt Head (AW-PH300) light red.
- 40 12V DC Input Connector [DC 12V IN] (DC Jack)**
Connect the AC Adapter AW-PS301 (optional).
- 41 Cord Clamp (Clamper)**
Clamps the DC cord of the AC Adapter AW-PS301 (optional) connected to DC 12V IN Connector 40 to prevent its disconnection.

- 42 Auxiliary Control Input Connector [AUX CONTROL IN] (8-pin DIN Connector)**
External control signals are input to this connector in controlling the head's pan/tilt, lens zoom, focus and iris operations.
Note: In externally controlling the pan/tilt head and lens through this connector, set IRIS LEVEL Control 25 on this control panel to the center point (straight up), and do not simultaneously operate SPEED Switch 29, ZOOM Lever 36, FOCUS LEVER 37, and PAN/TILT Lever 38. Operation errors may occur if external controls are simultaneously used.

8-pin DIN connector pin assignment (as viewed from the rear of the control panel)

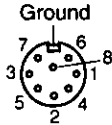

Example of auxiliary control circuit

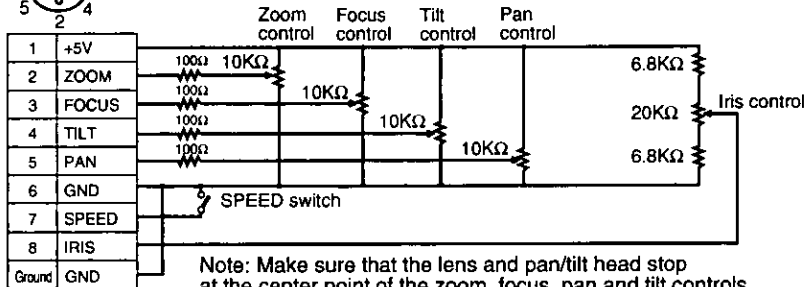

Note: Make sure that the lens and pan/tilt head stop at the center point of the zoom, focus, pan and tilt controls (or at the lever reset position if the controls have a lever reset function).

43 Preview Video Input Connector [TO MULTIPOINT HUB, PREVIEW IN] (BNC Connector)

Connect it to the preview video output connector [PREVIEW OUT] on the Multiport Hub with a coaxial cable (5C-2V or equivalent). The maximum allowable length of the cable is 10 meters.

44 Genlock Output Connector [TO MULTIPOINT HUB, G/L OUT] (BNC Connector)

Connect it to the G/L input connector [G/L IN] on the Multiport Hub with a coaxial cable (5C-2V or equivalent) in operating the camera in external sync mode. The cable can be extended up to 10 meters.

45 Camera Control Output Connector [TO MULTIPOINT HUB, CAMERA CONTROL OUT] (BNC Connector)

Connect it to camera control input connector [CAMERA CONTROL IN] on the Multiport Hub with a coaxial cable (5C-2V or equivalent), which may be extended up to 10 meters.

46 Pan/tilt Control Output Connector [TO MULTIPOINT HUB, PAN/TILT CONTROL OUT] (RJ-45 8-pin Modular Jack)

Connect it to pan/tilt control output connector [P/T CONTROL IN] on the Multiport Hub with a 10BASE-T straight cable (UTP category 5 or equivalent), which may be extended up to 10 meters.

47 Preview Video Output Connector [PREVIEW MONITOR OUT] (BNC Connector)

The video signals of the camera selected with CONTROL Switch ② are output from this connector so that the selected camera can be visually confirmed. Connect this connector to the monitor video input with a coaxial cable.

Note: The preview video signals are for confirmation of which camera has been selected, so the picture quality proper to the camera cannot be guaranteed. To output camera video signals, use video output connector [VIDEO OUT] or S-video output connector [S-VIDEO OUT] on the Multiport Hub.

48 Genlock Input Connectors [G/L IN] (BNC Connector)

Black burst signals or are input to one of the two connectors in operating the camera in external sync mode. The two connectors are automatically terminated, so input the above signals to one of them and use the other as a loop-through output.

■ Front Panel

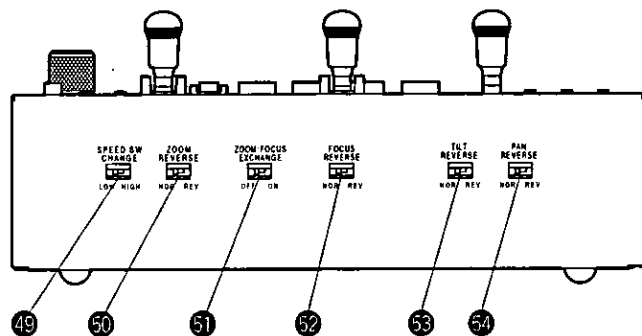

49 Speed Switch Changing Switch [SPEED SW CHANGE, LOW/HIGH]

Changes the polarity of SPEED Switch 29. If ZOOM lever 36, FOCUS Lever 37, or PAN/TILT Lever 38 is moved while keeping SPEED Switch 29 depressed, the corresponding operation takes place at low speed, provided that SPEED SW CHANGE Switch 49 is in the LOW position. If one of these levers is moved with SPEED Switch 29 depressed when SPEED SW CHANGE Switch 49 is in the HIGH position, the corresponding operation takes place at high speed.

The speed polarity can also be changed by pressing MEMORY Switch 27 while keeping SPEED Switch 29 depressed. When this step is taken again, the origi-

nal speed polarity is restored. Take this step if it is difficult to shift SPEED SW CHANGE Switch 49 because this control panel is mounted on a console or the like.

50 Zoom Reverse Switch [ZOOM REVERSE, NORM/REV]

Changes the operating direction of ZOOM Lever 36. The lens zoom moves toward TELE when ZOOM Lever 36 is moved toward TELE, or toward WIDE when it is moved toward WIDE, provided that ZOOM REVERSE Switch 50 is in the NOR position. When ZOOM REVERSE Switch 50 is set to the REV position, lens zoom operation takes place in the opposite direction. With ZOOM REVERSE Switch 50 in the

REV position, the operating directions shown on the panel are reversed. In this case, paste the supplied seal on the panel.

**51 Zoom/Focus Exchange Switch
(ZOOM/FOCUS EXCHANGE, ON/OFF)**

ZOOM Lever 36 and FOCUS Lever 37 exchange their function between them when this switch is set to the ON position. Unless this exchange is needed, keep the switch in the OFF position.

With ZOOM/FOCUS EXCHANGE Switch 51 in the ON position, the operations shown on the panel do not agree with the indications on the panel. In this case, paste the supplied seal on the panel.

**52 Focus Reverse Switch
[FOCUS REVERSE, NOR/REV]**

Changes the operating direction of FOCUS Lever 37. The lens is focused far when FOCUS Lever 37 is moved toward FAR, or near when the lever is moved toward NEAR, provided that FOCUS REVERSE Switch 52 is in the NOR position. When FOCUS REVERSE Switch 52 is set to the REV position, the lens focus operates in the opposite direction.

With FOCUS REVERSE Switch 52 in the REV position, the operating directions shown on the panel are opposite to the indications on the panel. In this case, paste the supplied seal on the panel.

53 Tilt Reverse Switch [TILT REVERSE, NOR/REV]

Changes the tilt direction controlled by PAN/TILT Lever 38. The pan/tilt head turns up when PAN/TILT Lever 38 is moved toward UP, or down when it is moved toward DOWN, provided that TILT REVERSE Switch 53 is in the NOR position. The pan/tilt head moves in the opposite direction if the TILT REVERSE Switch 53 is in the REV position.

With TILT REVERSE Switch 53 in the REV position, the operating directions shown on the panel are opposite to the indications on the panel. In this case, paste the supplied seal on the panel.

54 Pan Reverse Switch [PAN REVERSE, NOR/REV]

Changes the pan direction controlled by PAN/TILT Lever 38. The pan/tilt head turns leftward when PAN/TILT Lever 38 is moved toward LEFT, or rightward if it moved toward RIGHT. The rotary head turns in the opposite direction if the PAN REVERSE Switch 54 is in the REV position, provided that PAN REVERSE Switch 54 is in the NOR position. When PAN REVERSE Switch is set to the REV position, the pan/tilt head turns in the opposite directions.

With PAN REVERSE Switch 54 in the REV position, the operating directions shown on the panel are opposite to the indications on the panel. In this case, paste the supplied seal on the panel.

Note: TILT REVERSE Switch ⑬ and PAN REVERSE Switch ⑭ may be used to reverse the operating direction of the pan/tilt head, but be sure to set the operating direction of the pan/tilt head with its mounting direction selection switch during its installation depending on whether the pan/tilt head is mounted on the floor or is suspended. Unless the mounting direction selection switch on the pan/tilt head is properly set, the pan/tilt head will pan or tilt in the opposite direction and the pan/tilt head operation limiters will not be properly stored in the memory. For details on the setting of this switch, refer to INSTALLATION OF PAN/TILT HEAD at page 19 or the Operating Instructions for the Pan/tilt Head.

INSTALLATION OF PAN/TILT HEAD

- Install the pan/tilt head after carefully reading the Operating Instructions for Pan/tilt Head.
- Have four hex bolts (M6 x 4) ready for mounting the pan/tilt head. Select bolts of a length appropriate to the material and structure of the mounting base and the overall weight applied to it. Fasten the bolts securely with plain washers, spring washers, and hex nuts. If the bolts are not securely tightened, the pan/tilt head might fall to cause injuries or accidents. In case of suspending the pan/tilt head, locally purchase a wire rod strong enough to hold the pan/tilt head, camera, and lenses, pass it through the wire hole opened in a firm board, such as of the ceiling, for example, and fasten it securely.
- The switches on the pan/tilt head have been preset before shipment from the factory on the assumption that the pan/tilt head would be suspended from the ceiling. If the pan/tilt head is mounted on a board, for example, be sure to shift the mounting direction switches on the pan/tilt head. Unless this is done, pan/tilt directions will be reversed and pan/head operation limiter data cannot be properly stored in the memory. For details on shifting these switches, refer to the Operating Instructions for Pan/tilt Head.

Have a strong enough wire rod head and fasten it securely to a firm board, such as of the ceiling.

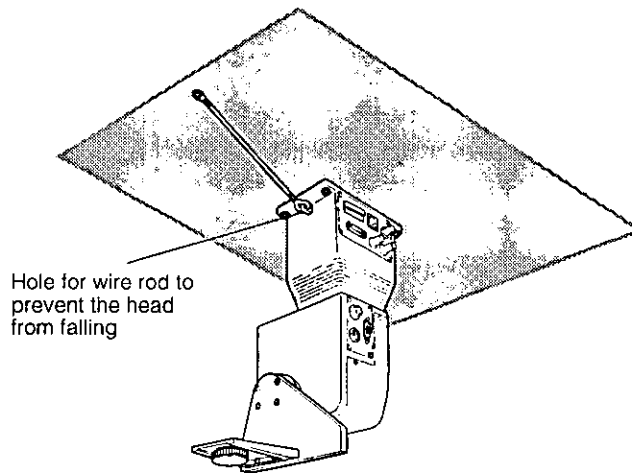

- **Changing Switch Settings on Pan/tilt Head**

- ① Remove the cover from the pan/tilt head.
 - Be careful of the Tally Indicator wire.

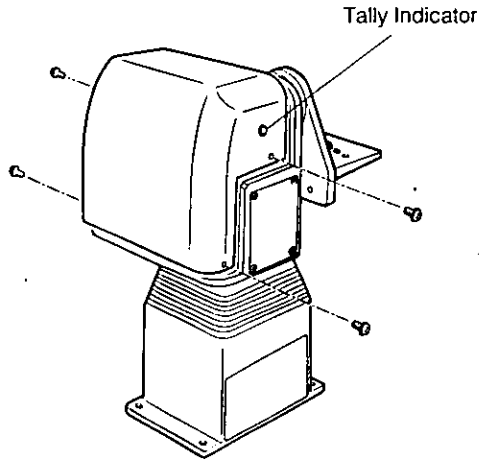

- ③ Place the cover back on the pan/tilt head.
 - Be sure not to trap the wires.

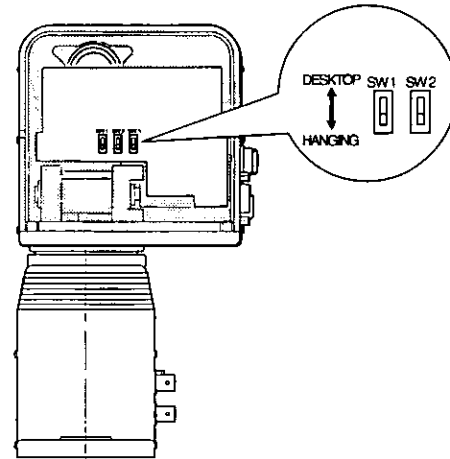

- ② Shift the mounting direction switches (SW1, SW2) on the pan/tilt head depending on whether the head is suspended from the ceiling or mounted on the floor. They are originally set for suspended installation.
 - Do not change the original set position of SW3. If it is changed, no operation can be controlled from the control panel.

- If the pan/tilt head is connected to the multiport hub with a cable longer than 300 meters, set the cable compensation switch on the pan/tilt head to the ON position in advance. If the distance between the pan/tilt head and the control panel is shorter than 300 meters, keep the switch in the original position (OFF). For details on shifting the switch, refer to the figure below or the Operating Instructions for Pan/tilt Head.

- **Shifting Cable Compensation Switch on Pan/tilt Head**

If the distance from the control panel to the pan/tilt head is longer than 300 meters, set the cable compensation switch to the ON position by observing the following procedure.

- ① Remove the controller connection panel from the pan/tilt head.
 - * Be careful of the wires.
- ② Shift the cable compensation switch on the inner side of the controller connection panel of the pan/tilt head to the ON position.
- ③ Place the controller connection panel back on the pan/tilt head.

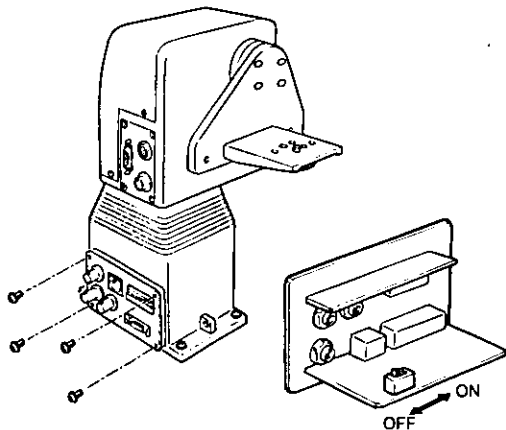

- **How to Mount the Lens**

- Turn the lens lock ring knob fully counterclockwise.
- If the lens mount has a cap, remove the cap.
- With the lens positioning pin up, mount the lens.
- Turn the lens lock ring knob clockwise till the lens is securely fastened.

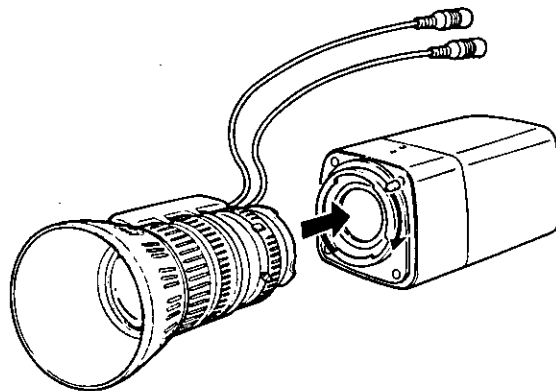

CONNECTIONS

- Before making any connection, switch off all the components of the system.
- Use the Control Panel AC Adaptor AW-PS301 (optional), Multiport Hub AC Adaptor AW-PS505 (optional) and Pan/tilt Head AC Adaptor AW-PS300 (optional).

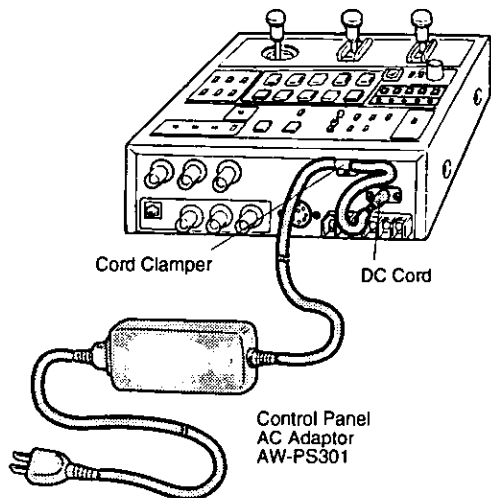

- Use the Multiport Hub AW-HB505, the Pan/tilt Head AW-PH300 and the Color Video Camera AW-E560. (The Color Video Camera WV-E550 cannot be used.) To connect the pan/tilt head to the camera, the Camera Cable AW-CA20T15 (optional) is necessary.
- Locally purchase a DC cable with a nominal cross section of 1.25 mm² or larger that meets the UL specifications, and connect the Pan/tilt Head AW-PH300 to the Pan/tilt Head AC Adaptor AW-PS300 with that cable. The maximum distance between the pan/tilt head and pan/tilt head AC adapter is 30 m.
- Connect the Multiport Hub AC Adapter AW-PS505 to the Multiport Hub AW-HB505.
- Connect the AC Adaptor AW-PS301 to the control panel and clamp the DC cable of the AC adapter to the cord clamp on the control panel.
- Connect the Pan/tilt Head AW-PH300 to the Color Video Camera WV-E560 with the Camera Cable AW-CA20T15.

- Connect the iris control cable of the motor-driven zoom lens to the camera and the remote (zoom/focus control) cable to the pan/tilt head. If the remote (zoom/focus control) cable of the motor-driven zoom lens is connected to the camera, the lens cannot be controlled.

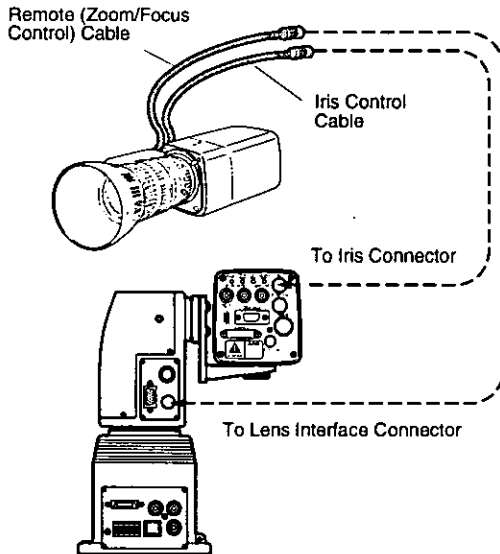

- Connect the control panel to the multiport hub with the three coaxial cables (video signal, G/L signal, camera control signal) and one 10BASE-T straight cable (pan/tilt head control signal). The maximum distance between the control panel and pan/tilt head is 10 meters for coaxial cables 5C-2V and 10BASE-T straight cable (UTP category 5 or equivalent).
- Connect the pan/tilt head to the multiport hub with the three coaxial cables (video signal, G/L signal, camera control signal) per pan/tilt head and one 10BASE-T straight cable (pan/tilt head control signal). The maximum distance between the control panel and pan/tilt head is 500 meters per pan/tilt head for coaxial cables 5C-2V and 10BASE-T straight cable (UTP category 5 or equivalent).
- For further details on connecting the individual devices,

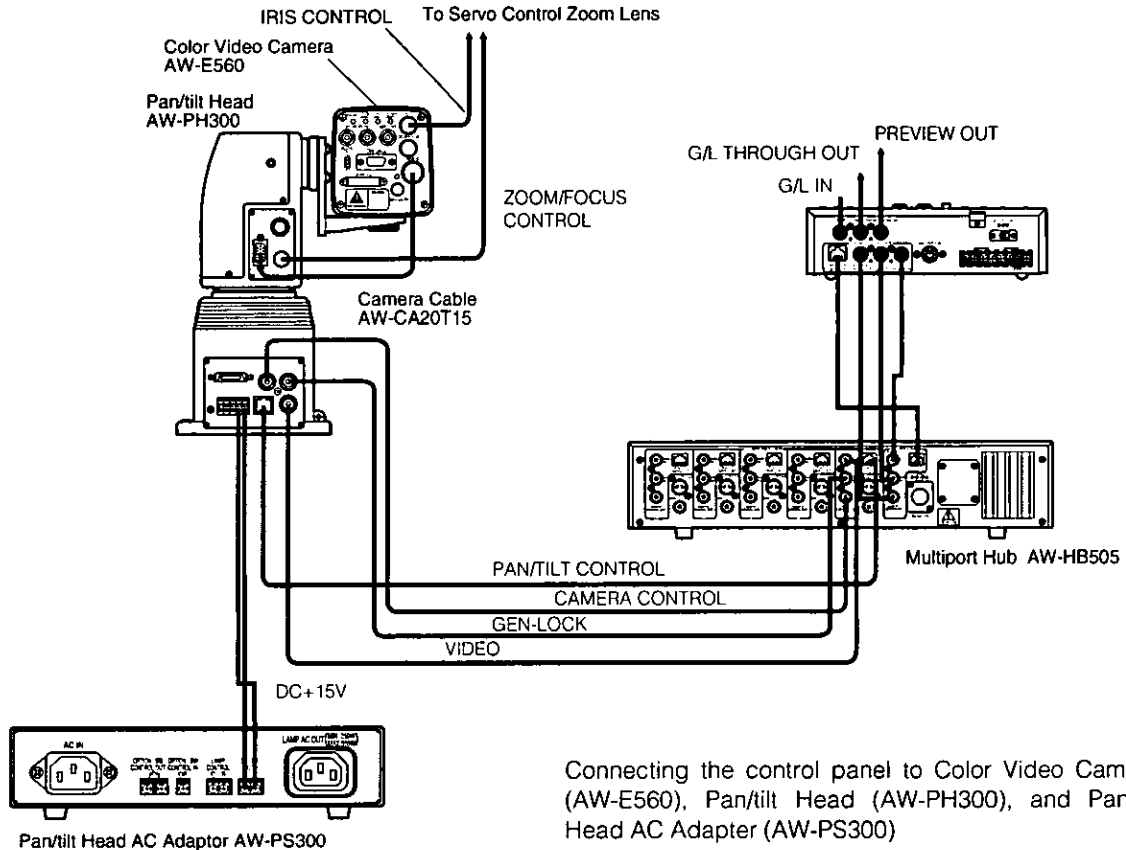

• Example of System Configuration

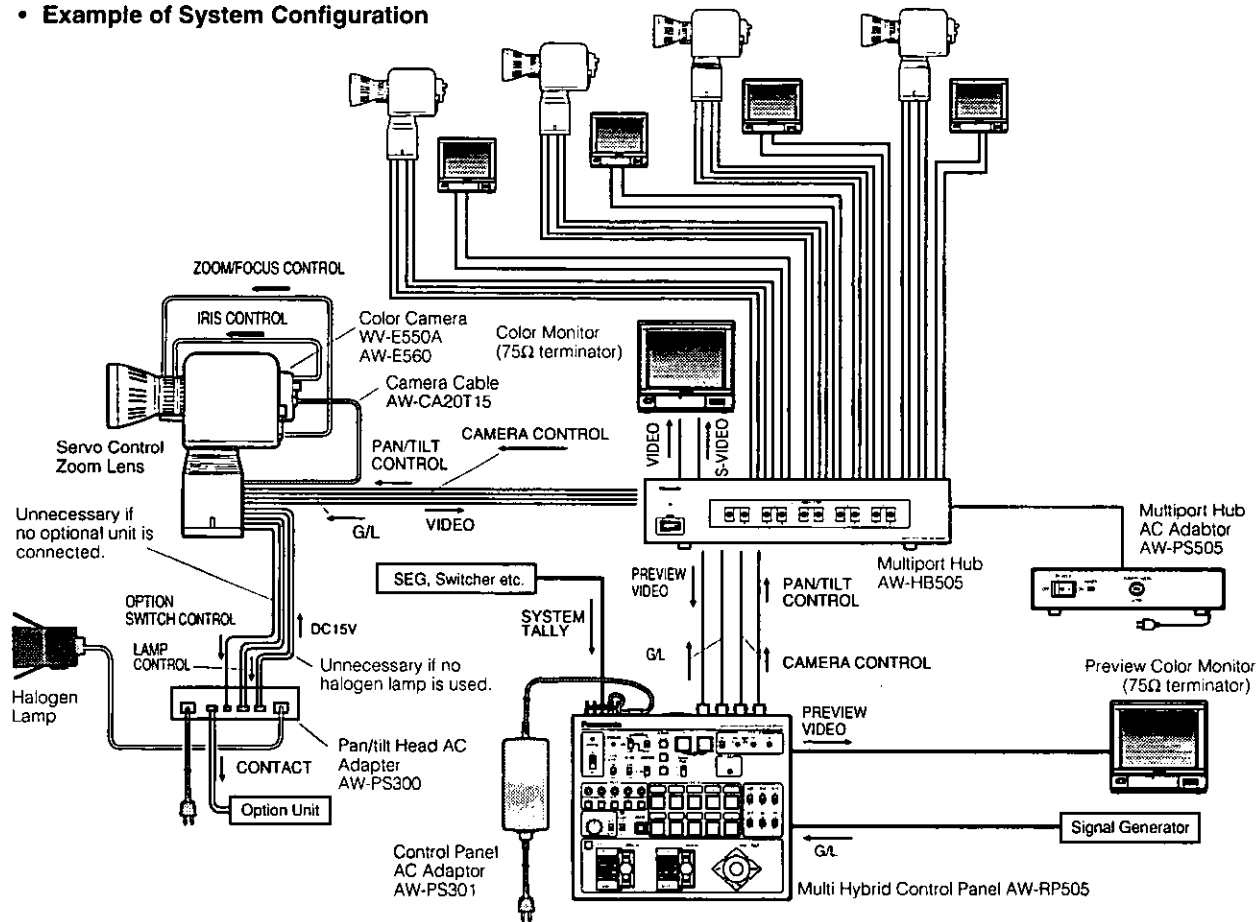

OPERATING PROCEDURES

1. Power

Press the power switch on each pan/tilt head AC adapter and the power switch on the multiport hub AC adapter to the ON position, then press the power switch on the multiport hub to the ON position. Finally, press the power control switch on the multi hybrid control panel to the ON position.

2. Pan/tilt Limiter Setting for Each Pan/tilt Heads

If there are obstacles around the pan/tilt head, set the limiters to limit the operating range (pan left and right ends, tilt up and down ends) of the pan/tilt head.

Note: The switches on the pan/tilt head have been pre-set before shipment from the factory on the assumption that the pan/tilt head would be suspended from the ceiling. If the pan/tilt head is mounted on a board, for example, be sure to shift the mounting direction switches on the pan/tilt head. Unless this is done, pan/tilt directions will be reversed and pan/head operation limiter data cannot be properly stored in the memory. For details on shifting these switches, refer to INSTALLATION OF PAN/TILT HEAD at page 19 or the Operating Instructions for Pan/tilt Head.

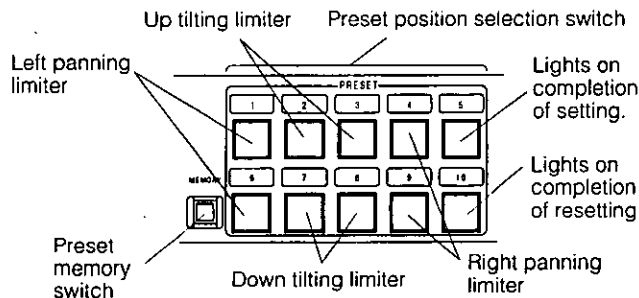

- ① Select a pan/tilt head with the CONTROL switch.
- ② Left Panning Limiter
Turn the pan/tilt head to the desired left panning limit with PAN/TILT Lever 38, keep MEMORY Switch 27 depressed, and simultaneously press buttons [1] and [6] of PRESET Switch 29 for 5 seconds or more. When the desired limit has been set, button [5] of PRESET Switch 28 lights.
To reset the limit, keep the MEMORY switch 27 depressed, and simultaneously press buttons [1] and [6] of PRESET Switch 29 again for 5 seconds or more. When the set limit is reset, button [10] of PRESET Switch 29 lights.

- ③ Right Panning Limiter
Turn the pan/tilt head to the desired right panning limit with PAN/TILT Lever ③⑧, keep MEMORY Switch ②⑦ depressed, and simultaneously press buttons [4] and [9] of PRESET Switch ②⑥ for 5 seconds or more. When the desired limit has been set, button [5] of PRESET Switch ②⑥ lights.

To reset the limit, keep the MEMORY Switch ②⑦ depressed, and simultaneously press buttons [4] and [9] of PRESET Switch ②⑥ again for 5 seconds or more. When the set limit is reset, button [10] of PRESET Switch ②⑥ lights.

- ④ Up Tilting Limiter

Turn the pan/tilt head to the desired up tilting limit with PAN/TILT Lever ③⑧, keep MEMORY Switch ②⑦ depressed, and simultaneously press buttons [2] and [3] of PRESET Switch ②⑥ for 5 seconds or more. When the desired limit has been set, button [5] of PRESET Switch ②⑥ lights.

To reset the limit, keep the MEMORY switch ②⑦ depressed, and simultaneously press buttons [2] and [3] of PRESET Switch ②⑥ again for 5 seconds or more. When the set limit is reset, button [10] of PRESET Switch ②⑥ lights.

- ⑤ Down Tilting Limiter

Turn the pan/tilt head to the desired down tilting limit with PAN/TILT Lever ③⑧, keep MEMORY Switch ②⑦ depressed, and simultaneously press buttons [7] and

[8] of PRESET Switch ②⑥ for 5 seconds or more. When the desired limit has been set, button [5] of PRESET Switch ②⑥ lights.

To reset the limit, keep the MEMORY switch ②⑦ depressed, and simultaneously press buttons [7] and [8] of PRESET Switch ②⑥ again for 5 seconds or more. When the set limit is reset, button [10] of PRESET Switch ②⑥ lights.

- ⑥ Select the pan/tilt heads with the CONTROL switch, one at a time, and set the operating range limiters of each pan/tilt head.

3. Cable Compensation Settings, Genlock, and Total Pedestal Adjustments for Each Cameras and Various Switch Settings

- 1) After selecting a camera with the CONTROL Switch ②②, set the CAM CONT Switch ④ to the ON position.

Note: When the CAM CONT Switch ④ on the multi hybrid control panel is set to the ON position, the switch settings of the multi hybrid control panel are sent to the camera to update its settings. Do not set the CAM CONT Switch ④ to the ON position except when changing the camera settings. If another camera is selected with the CONTROL Switch ②② while the CAM CONT Switch ④ is in the

ON position, the settings of the selected camera will be similarly changed. Set the CAM CONT Switch ④ back to the OFF position before changing one camera for another with the CONTROL Switch ②.

2) Adjust the cable compensation, genlock, and total pedestal of the selected camera.

• Cable Compensation

Signal degradation due to cable length between the multiport hub and the pan/tilt head can be compensated for.

- ① If the cable length from the pan/tilt head to the multiport hub is longer than 300 meters, set the cable compensation switch on the pan/tilt head to the ON position. For details, refer to INSTALLATION OF PAN/TILT HEAD at page 19 or the Operating Instructions for Pan/tilt Head.
- ② Connect a waveform monitor or a vectorscope to the video output connector on the control panel for the corresponding camera pan/tilt head number ([1] to [5]), set the video output connector on the multiport hub, set the mode switch to the BAR position, then observe the color bar signals.
- ③ Adjust the Y (luminance) signal level with the CABLE COMP Y control for the corresponding camera pan/tilt head number ([1] to [5]), then adjust the CABLE COMP Y control then adjust the C (chrominance) signal level with CABLE COMP C control. Repeat this until

the video output of the multiport hub is adjusted as shown in the figure below.

Note: Turning CABLE COMP Y control changes not only the Y (luminance) signal level but also the video signal levels as a whole.

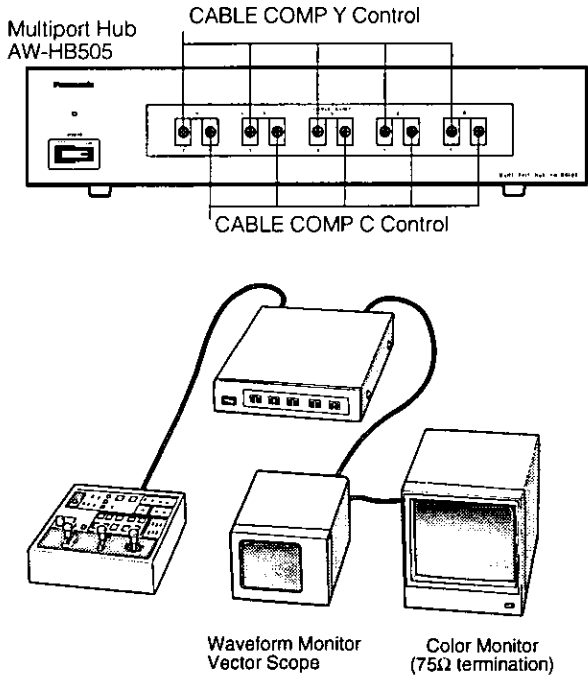

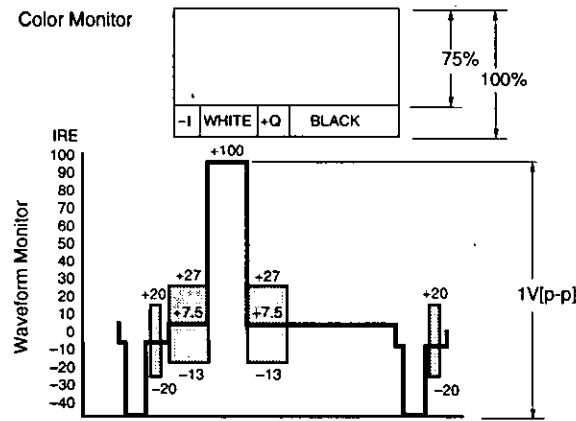
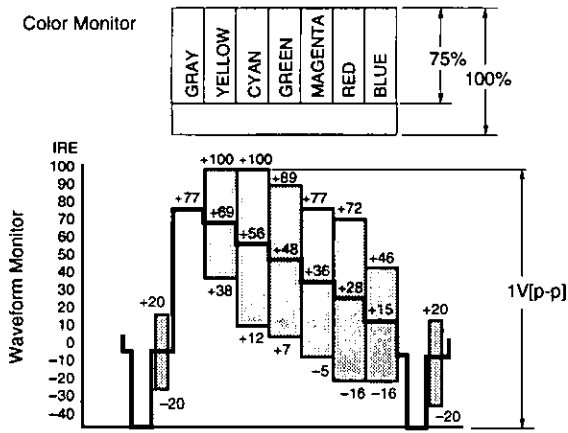

• Genlock Adjustment

To use the camera in external sync mode, phase adjustment is necessary to match the phases with those of the other units and camera. No G/L adjustment is necessary in case of no genlock.

• Horizontal Phase Adjustment

- ① Set G/L PHASE ON/OFF Switch **16** to the ON position.
Note: When G/L PHASE ON/OFF Switch **16** is set to the ON position, the sync phase of the camera changes to the settings of G/L PHASE H Control **19**, G/L PHASE Coarse Switch **17**, and G/L PHASE SC Control **18**. Unless G/L phase adjustment is necessary, do not set G/L PHASE ON/OFF Switch **16** to the ON position.
- ② Observe the waveforms of the G/L signal input (black burst signal and video signal output on a dual channel oscilloscope, and turn the G/L horizontal phase control to match the horizontal phase as shown in the next page.

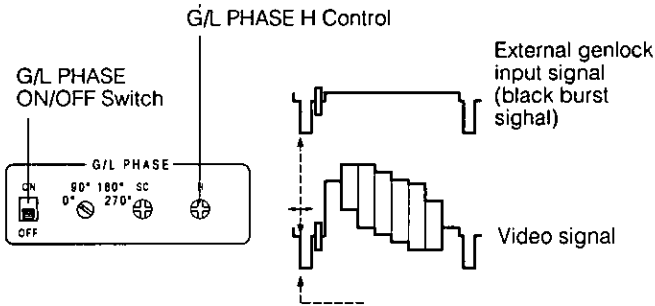

③ Set G/L PHASE ON/OFF Switch 15 back to the OFF position.

• **Subcarrier Phase Adjustment**

① Set G/L PHASE ON/OFF Switch 16 to the ON position.

Note: When G/L PHASE ON/OFF Switch 16 is set to the ON position, the sync phase of the camera changes to the settings of G/L PHASE H Control 19, G/L PHASE Coarse Switch 17, and G/L PHASE SC Control 18. Unless G/L phase adjustment is necessary, do not set G/L PHASE ON/OFF Switch 16 to the ON position.

② Adjust G/L PHASE Coarse Switch 17 and G/L PHASE SC Control 18 to match the subcarrier color phase of the video signal output with that of the reference tone, such as of the program output (split color bar output) of

a Color Special Effect Generator, for example. Higher accuracy can be obtained if a vectorscope is used for color phase adjustment.

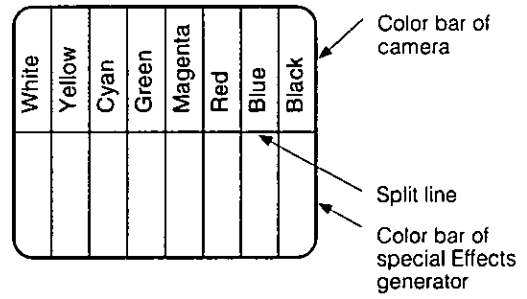
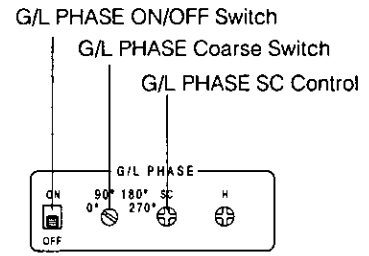

③ Set G/L PHASE ON/OFF Switch 16 back to the OFF position.

• Total Pedestal Adjustment

Total pedestal adjustment is made to adjust the pedestals of two or more cameras. Using an oscilloscope or a waveform monitor, adjust the pedestals to 5 IRE (0.035 V) or 7.5 IRE (0.050 V) with T.PED Control ⑳.

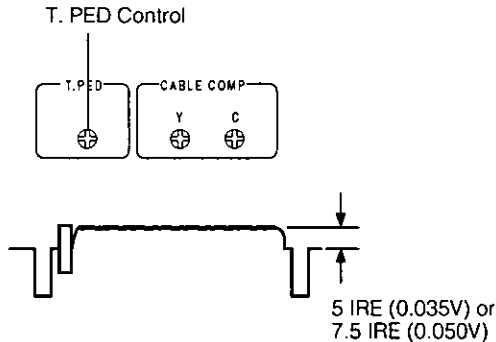

- 3) Set the switches for gain, shutter, etc. as appropriate to the conditions of using the camera.
- 4) Set the camera control switch on the multi hybrid control panel to the OFF position.
- 5) Repeat Steps 1) to 4) to finish cable compensation, G/L adjustment, total pedestal adjustment, and switch setting for all the cameras.

4. White Balance and Black Balance Setting

- 1) Select a camera with the CONTROL Switch ㉒ on the multi hybrid control panel.
- 2) Adjust the white balance and black balance of the selected camera.

- White balance adjustment is necessary when using the camera for the first time, or if the camera has not been used for a long period of time.
- Once the white balance is adjusted, no readjustment is necessary if the camera is used under the same conditions.

• Automatic White Balance Control (AWC)

The color temperature conditions for two channels A and B can be stored in the memory in advance. Once the white balance is adjusted, all that is needed is to select either AUTO/ATW A Switch ㉓ or AUTO/ATW B Switch ㉔ of the multi hybrid control panel. If the camera is used under the same conditions. No readjustment is necessary. If the white balance is readjusted, the existing white balance data is replaced with new data.

- ① Press either AUTO/ATW A Switch ㉓ or AUTO/ATW B Switch ㉔ of the multi hybrid control panel.

② Pick up a white object (a white wall or white handkerchief, for example) fully on the screen. Be careful to keep a shiny or bright object out of the screen.

③ When AWC Switch ⑫ of the multi hybrid control panel is pressed, the auto set LED flashes and the white balance is automatically adjusted. It goes out when it has been properly adjusted. If the adjustment fails, the LED remains lit. In such a case, change the brightness, iris, object, light source, etc. and adjust it again.

• **Automatic Tracing White Balance Control (ATW)**

When AUTO/ATW ATW Switch ⑨ of the multi hybrid control panel is pressed, the white balance is automatically adjusted even if the light source or color temperature changes, thus reproducing a natural image.

Note: The white balance may deviate if there is nothing white in the image. The white balance may not be fully adjusted depending on the light source or color temperature.

- Black balance adjustment is necessary when using the camera for the first time, or if the camera has not been used for a long period of time.
- Black balance adjustment is necessary if there is a big change in the ambient temperature or at the turn of a season.
- Once the black balance is adjusted, no readjustment is necessary if the camera is used under the same conditions.

• **Automatic Black Balance Control (ABC)**

When ABC Switch ⑬ of the multi hybrid control panel is pressed, the lens iris is automatically closed to set the black balance. Keep IRIS AUTO/MANU Switch ⑳ of the multi hybrid control panel in the AUTO position when setting the black balance. The auto set LED flashes during black balance adjustment, and goes out when it is finished normally. The LED remains lit if the adjustment fails. In such a such, try to adjust it again. Black balance adjustment may fail in some cases where the total pedestal is too low. Adjust the total pedestal with T.PED Control ㉑ of the multi hybrid control panel and adjust the black balance again.

3) Repeat Steps 1) and 2) to adjust the white balance and black balance of all the cameras.

5. Camera and Pan/tilt Head Presetting

- 1) Select a desired operating camera and pan/tilt head with the CONTROL switch ②.
- 2) Pick up a desired object with the camera using PAN/TILT Lever ③, ZOOM Lever ⑥ and FOCUS Lever ⑦. Select a white balance control mode using AUTO/ATW ATW Switch ⑨, AUTO/ATW A Switch ⑩ or AUTO/ATW B Switch ⑪. To store iris data in the memory, set IRIS AUTO/MANU Switch ⑫ to the MANU position and turn the iris control. When IRIS AUTO/MANU Switch ⑫ is in the AUTO position, iris data will not be stored in the memory.
- 3) Keep MEMORY Switch ⑭ depressed (MEMORY Switch ⑭ lights and all the 10 buttons of PRESET Switch ⑮ flash), press any of the buttons [1] to [10] of PRESET Switch ⑮ as desired to store the data in the memory. Only that button of PRESET Switch ⑮ where the data is stored lights.
Note: If data is stored again in the same button of PRESET Switch ⑮ the preceding data is deleted.
- 4) Repeat Steps 1) and 2) to store the presettings of all the cameras and pan/tilt head in the memory.

6. Various Switch Settings

Select a desired operating camera and pan/tilt head with the CONTROL switch ②, then control the camera and pan/tilt head using PRESET Switch ⑮, PAN/TILT Lever ③, ZOOM Lever ⑥, FOCUS Lever ⑦, IRIS AUTO/MANU Switch ⑫ and other switches.

- * In case of not changing the adjustment data and settings, it is not necessary to repeat the adjustment and setting procedures described in Sections 2 to 6.

RACK MOUNTING

■ Rack Mounting

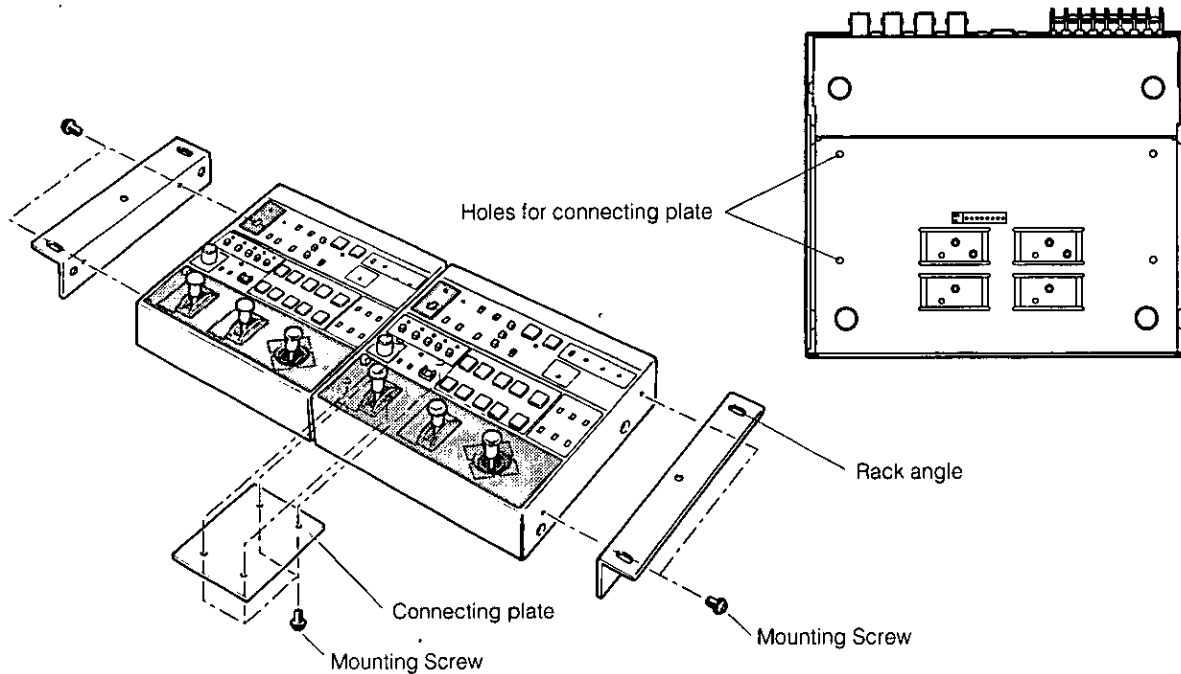

■ How to Change Rear Panel Direction

- ① Remove the four screws from both sides of the top cover, and take the top cover off.

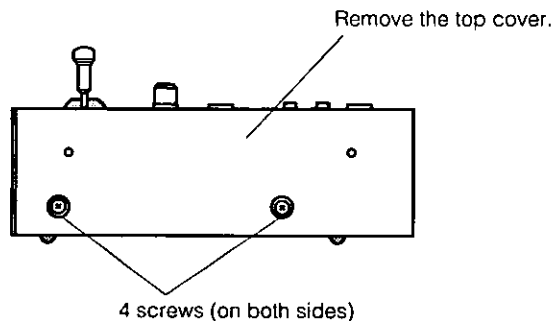

- ② Remove the two screws and take the blank panel off.

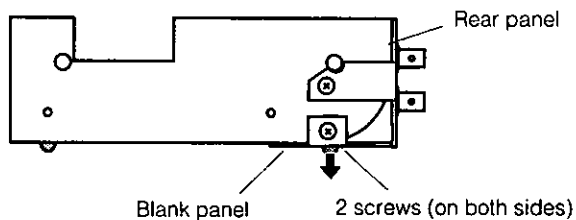

- ③ Loosen the rear panel screw, turn the rear panel down, and fasten it to the bottom.

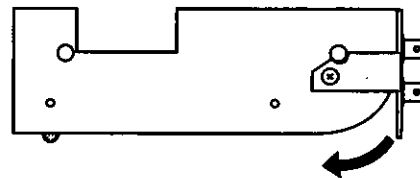

- ④ Fasten the blank panel back to the rear.

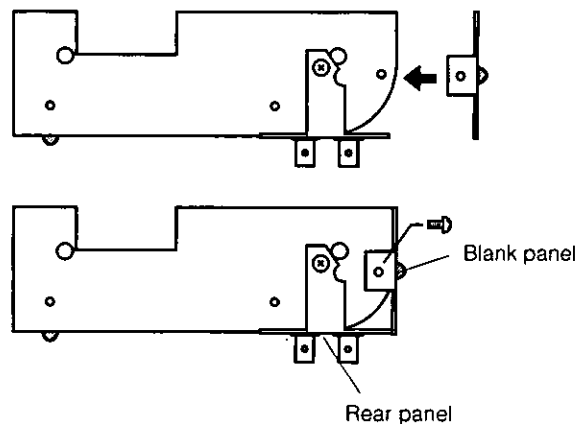

SPECIFICATIONS

Source Voltage	12 V DC (DC jack)
Power Consumption	12V, 0.5A
Preview Video Input	1.0 V[p-p] composite/75Ω (BNC connector)
Genlock Input	1.0 V[p-p] black burst 75Ω loop through with auto terminator (BNC connector)
Preview Video Output	1.0 V[p-p] composite/75Ω (BNC connector)
Genlock Output	75Ω (BNC connector)
Camera Control Output	Control signal (BNC connector)
Pan/tilt Control Output	Control signal (RJ-45 8P modular jack)
System Tally Input	Tally signal (6 pin Terminal block)
Auxiliary Control Input	Control signal (8 pin DIN connector)
Switches	Power ON/OFF Switch, CAM CONT Switch, GAIN HIGH/MID/LOW Switch, GAIN AGC/MANU Switch, SCENE FILE Switch, CONTROL Switch, LAMP Switch, MODE BAR/CAM Switch SHUTTER Switch, AUTO/ATW ATW Switch, AUTO/ATW A Switch, AUTO/ATW B Switch, AWC Switch, ABC Switch, G/L PHASE ON/OFF Switch, G/L PHASE Coarse Switch, IRIS AUTO/MANU Switch, MEMORY Switch, PRESET Switch, DEF Switch, WIP Switch, H/F Switch, EXT Switch, ND Switch, OP Switch, SPEED Switch, T. PED Control, G/L PHASE SC Control, G/L PHASE H Control, IRIS LEVEL Control, ZOOM Lever, FOCUS Lever, PAN/TILT Lever
Controls	
Multiport Hub Connecting	
Cable:	x 4 (Coaxial Cable 3 pcs., 10BASE-T straight cable 1 pc.)(In case of using G/L function)
Maximum cable length:	10 m (In case of using coaxial cables 5C-2V and 10BASE-T straight cable UTP category-5)
Operating temperature	-10°C to +45°C (14°F to +113°F)

Dimensions	210 (W) x 88 (H) x 177 (D) mm [8-1/4" (W) x 3-1/2" (H) x 7" (D)]
Weight	2.2 kg (4.9 lbs.)
Finish	AV Ivory painting

Weight and dimensions indicated are approximate.
 Specifications are subject to change without notice.

ACCESSORIES

Seal	1	Mounting screws	12
Rack angle.....	2	M4 x 8mm	8
Connect plate	1	M5 x 8mm	4

Panasonic

Broadcast & Television Systems Company

Division of Matsushita Electric Corporation of America

Executive Office: One Panasonic Way 3F-5, Secaucus, NJ 07094

Regional Offices:

EASTERN ZONE: 50 Meadowlands Parkway, Secaucus, NJ 07094 (201) 348-7620

CENTRAL ZONE: 1707 North Randall Road, Elgin, IL 60123 (847) 468-5200

SOUTHERN ZONE:

Atlanta Region: 1225 Northbrook Parkway, Suite 1-160, Suwanee, GA 30024

Panazip 11 (770) 338-6841, fax (770) 338-6741

Law Enforcement Video Products: 1225 Northbrook Parkway, Suite 1-160, Suwanee, GA

30024, Panazip 11 (770) 338-6844, fax (770) 338-6721

WESTERN ZONE:

Seattle Region: 1200 Westlake Ave., North, Suite 508, Seattle, WA 98109 (206) 285-8883

Los Angeles Region: 6550 Katella Ave. 17A-1, Cypress, CA 90630 (714) 373-7271

Government Marketing Department: 52 West Gude Drive, Rockville, MD 20850 (301) 738-3840

PANASONIC CANADA INC.

5770 Ambler Drive, Mississauga, Ontario, L4W 2T3 Canada (905) 624-5010

PANASONIC SALES COMPANY

DIVISION OF MATSUSHITA ELECTRIC OF PUERTO RICO, INC.

San Gabriel Industrial Park, 65th Infantry Ave. KM. 9.5 Carolina, Puerto Rico 00630 (809) 750-4300

N1197-0

7J1A106A

Printed in Japan